

SPEED Activity Sheet 1



To find the speed of an object we need to know how far it has travelled and how long it took to travel this distance. Speed is measured in a variety of units, for example, metres per second (m/s) or kilometres per hour (km/h).

$$\text{SPEED} = \frac{\text{DISTANCE}}{\text{TIME}}$$

Speed – time graphs

The speed of an object can be shown on a graph by plotting speed against time. The steeper the line, the greater the change in speed.

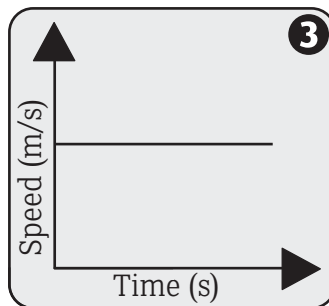
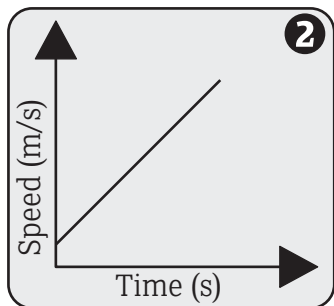
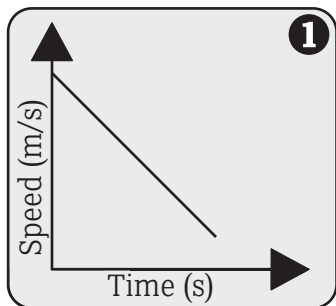

- 1** This graph shows an object slowing down.
- 2** This graph shows an object speeding up.
- 3** This graph shows an object moving at a constant speed.

Activity 1

If Rita, Queen of Speed is travelling at 90km/h, what is this speed in m/s?

Note: Distance = 90,000m
Time = 3,600s



Activity 2

Oblivion is a vertical plunge ride. The car is taken slowly to the top of the tower where it stops briefly before accelerating down the vertical plunge.

This graph shows speed against time for Oblivion between points A and B. Mark points 1,2,3 and 4 shown on the diagram to the left, on the graph.

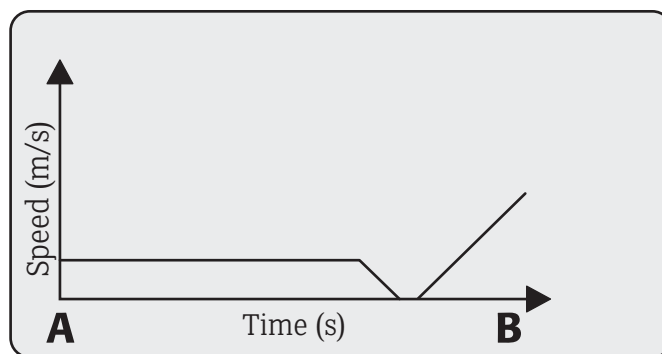
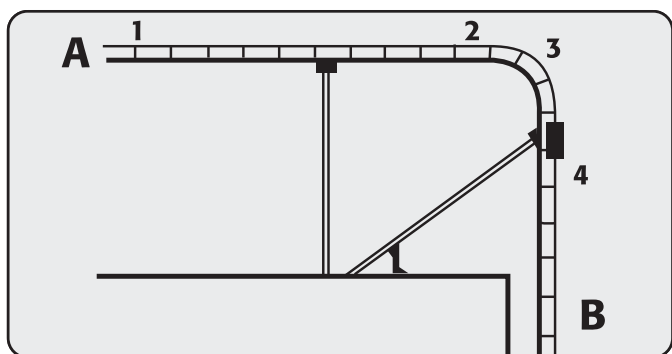

SPEED Activity Sheet 2



Activity 1

This table shows you the top speed of some of the rides at Alton Towers Resort.

Name of ride	Nemesis	Air	Oblivion	Rita	The Flume	Skyride
Total g-force	4g	3.5g	4.5g	4.7g	n/a	n/a
Track length	716m	850m	373m	647m	886m	1048m
Height drop	13m	20m	60m	18.4m	26m	61m
Ride duration	90s	85s	50s	49s	360s	300s
Maximum speed	81km/h	72km/h	110km/h	100km/h	55km/h	14km/h
Capacity per ride	46	28	16	20	5	10
Capacity per hour	1,061	1,200	1,562	1,150	1,172	1,352
Average speed						
Mass fully loaded	9,000kg	14,000kg	12,000kg	8,966kg	750kg	n/a

- A** Which of the rides is fastest? _____
- B** Look at the graph below showing the top speed of each of these rides.
- C** What is the average speed for each of the rides? Complete the table above with your answers.

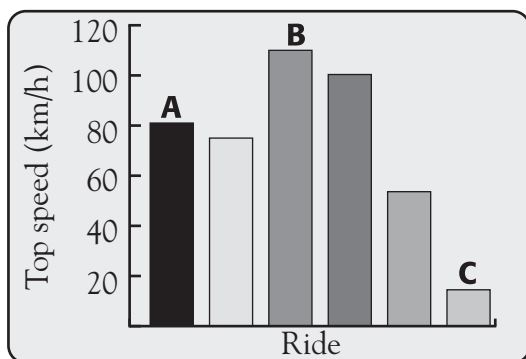

- i** Which ride is shown by column A?

- ii** Which is shown by column B?

- iii** Which is shown by column C?

- iv** Match the rest of the rides to the graph.

Show your workings

- D** Use the data in the table to make some game cards in the style of 'Top Trumps'.



Activity 1 Quick Test

A What are the two measurements required to calculate speed?

1

2

B Name two units to measure speed.

1

2

Activity 2

$$SPEED = \frac{DISTANCE}{TIME}$$

Using the formula above work out the quantities to go in the spaces in the table.

Ride	Distance travelled	Time taken	Average speed
Nemesis	400m	20s	
Oblivion		5s	20 m/s
Rita	100m		13.2 m/s
The Flume	500m	125s	
Skyride		5mins	12km/h

Activity 3

Skyride is travelling at 4 m/s. Brakes are applied to bring the ride to a halt at the next station. The graph shows how the speed of Skyride changes.

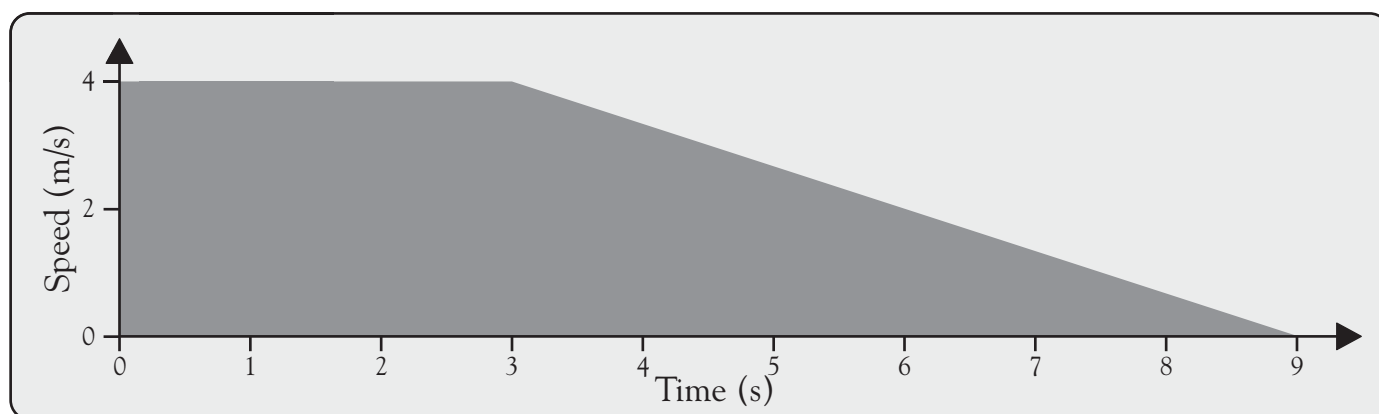

A How far did Skyride travel before the brakes were applied?

B After the brakes were applied, how long did it take for Skyride to stop?

C The average speed while Skyride was braking was 2 m/s. Calculate the distance Skyride travelled after the brakes were applied.

D What was the total stopping distance?
